



Cat[®] 259D

COMPACT TRACK LOADER

FEATURES:

The Cat[®] 259D Compact Track Loader, with its vertical lift design, delivers extended reach and lift height for quick and easy truck loading. Its standard, suspended undercarriage system provides superior traction, flotation, stability and speed to work in a wide range of applications and underfoot conditions. The 259D features the following:

- **Industry leading sealed and pressurized cab option** provides a cleaner and quieter operating environment with excellent work tool visibility.
- **Available high-back, heated, air ride seat with seat mounted adjustable joystick controls** makes the D Series the industry leader in operator comfort.
- **High performance power train** provides maximum performance and production capability through the Electronic Torque Management system, standard two speed travel and an industry exclusive electronic hand/foot throttle with decel pedal capability.
- **High Flow hydraulic system** is available for applications that demand maximum hydraulic work tool performance.
- **Electronically controlled Cat C3.3B engine** provides high horsepower and torque while meeting U.S. EPA Tier 4 Final (EU Stage IIIB) emission standards.
- **Cat "Intelligent Leveling" system (ILEV)** provides industry leading technology, integration and optional features such as work tool return to dig and work tool positioner.
- **Standard fully independent torsion axle suspension** combined with the optional Speed Sensitive Ride Control system improves operation on rough terrain, enabling better load retention, increased productivity and greater operator comfort.
- **Maximize machine capability and control** with optional Advanced Display providing on-screen adjustments for implement response, hystat response and creep control. Also features multi-language functionality with customizable layouts, security system and rearview camera.
- **Ground level access** to all daily service and routine maintenance points helps reduce machine downtime for greater productivity.
- **Broad range of performance matched Cat Work Tools** make the Cat Compact Track Loader the most versatile machine on the job site.

Specifications

Engine

Engine Model	Cat C3.3B DIT (turbo)	
Gross Power SAE J1995	55.4 kW	74.3 hp
Net Power SAE 1349	54.6 kW	73.2 hp
Net Power ISO 9249	55.1 kW	73.9 hp
Peak Torque at 1,500 rpm SAE J1995	265 N·m	195 lbf·ft
Displacement	3.3 L	203 in ³
Stroke	120 mm	4.7 in
Bore	94 mm	3.7 in

Weights*

Operating Weight (320 mm/12.6 in tracks)	4013 kg	8,846 lb
Operating Weight (400 mm/15.7 in tracks)	4057 kg	8,945 lb

Power Train

Travel Speed (Forward or Reverse)		
One Speed	9.5 km/h	5.9 mph
Two Speed	13.7 km/h	8.5 mph

*Operating Weight, Operating Specifications and Dimensions all based on 75 kg (165 lb) operator, all fluids, two speed, OROPS, 1676 mm (66 in) dirt bucket, 320 mm (12.6 in) tracks, dual flange front idler/single flange rear idler, standard flow hydraulics, mechanical suspension seat, no optional counterweights and manual quick coupler (unless otherwise noted).

Hydraulic System

Hydraulic Flow – Standard:			
Loader Hydraulic Pressure	23 000 kPa	3,335 psi	
Loader Hydraulic Flow	76 L/min	20 gal/min	
Hydraulic Power (calculated)	29 kW	39 hp	
Hydraulic Flow – High Flow:			
Loader Hydraulic Pressure	23 000 kPa	3,335 psi	
Loader Hydraulic Flow	112 L/min	30 gal/min	
Hydraulic Power (calculated)	43 kW	58 hp	

Operating Specifications*

Rated Operating Capacity:			
35% Tipping Load	921 kg	2,030 lb	
50% Tipping Load	1315 kg	2,900 lb	
Rated Operating Capacity with Optional Counterweight			
Tipping Load	2631 kg	5,800 lb	
Breakout Force, Tilt Cylinder	2284 kg	5,035 lb	
Ground Contact Area (320 mm/12.6 in track)	0.96 m ²	1,483 in ²	
Ground Contact Area (400 mm/15.7 in track)	1.19 m ²	1,848 in ²	
Ground Pressure (320 mm/12.6 in track)	41.1 kPa	6.0 psi	
Ground Pressure (400 mm/15.7 in track)	33.4 kPa	4.8 psi	



259D Compact Track Loader

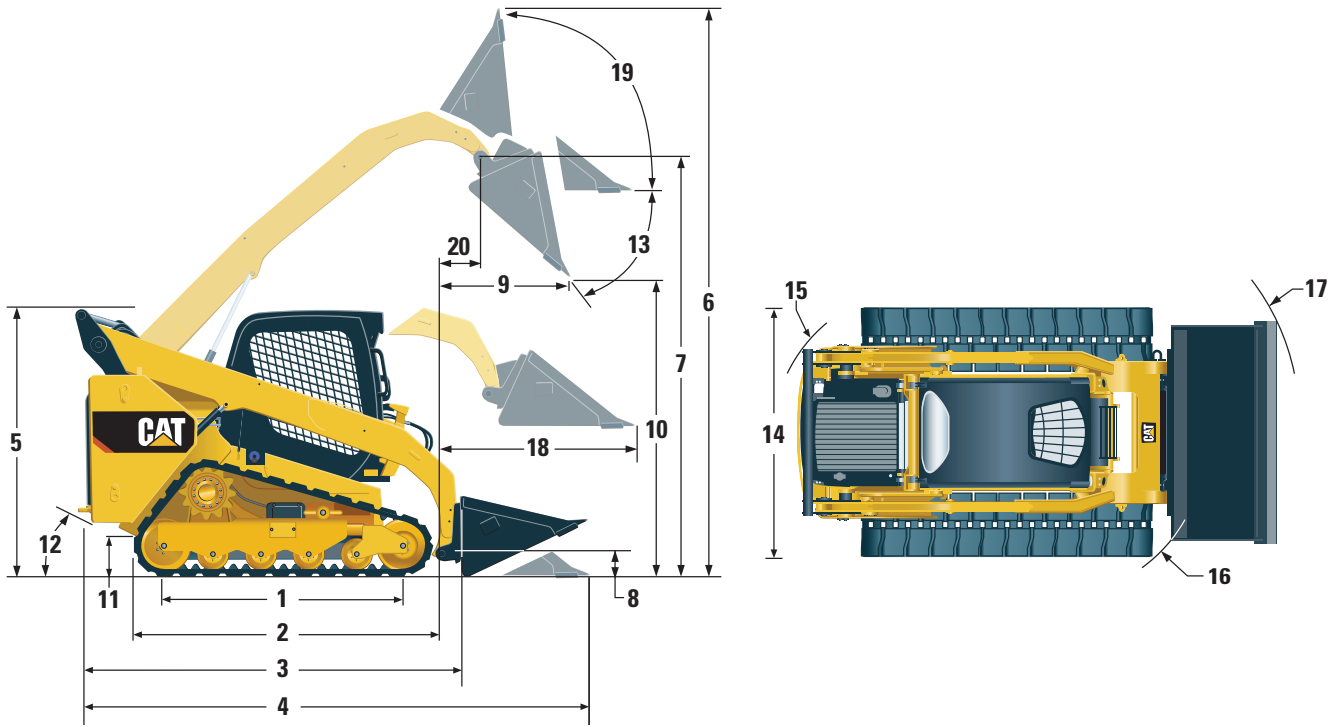

Dimensions*

1	Length of Track on Ground	1499 mm	59.0 in
2	Overall Length of Track	1999 mm	78.7 in
3	Length without Bucket	2767 mm	108.9 in
4	Length with Bucket on Ground	3486 mm	137.3 in
5	Height to Top of Cab	2111 mm	83.1 in
6	Maximum Overall Height	3915 mm	154.1 in
7	Bucket Pin Height at Maximum Lift	3075 mm	121.0 in
8	Bucket Pin Height at Carry Position	198 mm	7.8 in
9	Reach at Maximum Lift and Dump	608 mm	23.9 in
10	Clearance at Maximum Lift and Dump	2283 mm	89.9 in
11	Ground Clearance	226 mm	8.9 in
12	Departure Angle		35°
13	Maximum Dump Angle		52°
14	Vehicle Width (320 mm/12.6 in tracks)	1676 mm	66.0 in
	Vehicle Width (400 mm/15.7 in tracks)	1755 mm	69.0 in
15	Turning Radius from Center – Machine Rear	1561 mm	61.5 in
16	Turning Radius from Center – Coupler	1392 mm	54.8 in
17	Turning Radius from Center – Bucket	2184 mm	86.0 in
18	Maximum Reach with Arms Parallel to Ground	1305 mm	51.4 in
19	Rack Back Angle at Maximum Height		87°
20	Bucket Pin Reach at Maximum Lift	238 mm	9.4 in

Cab

ROPS	ISO 3471:2008
FOPS	ISO 3449:2005 Level I
FOPS Level II	ISO 3449:2005 Level II

Service Refill Capacities

Cooling System	14 L	3.7 gal
Engine Crankcase	11 L	3.0 gal
Fuel Tank	105 L	27.7 gal
Hydraulic System	50 L	13.2 gal
Hydraulic Tank	39 L	10.3 gal

MANDATORY EQUIPMENT

- Hydraulics, Standard or High Flow
- Quick Coupler, Mechanical or Electric
- Seat Belt, 50 mm (2 in) or 75 mm (3 in)
- EU Preparation Package (includes Demand Fan) (Europe only)
- Steel Imbed Rubber Track – 320 mm (12.6 in) or 400 mm (15.7 in)
- Dual Flange Front Idler/Single Flange Rear Idler or Triple Flange Front/Rear Idlers

PERFORMANCE PACKAGE *(must select one of the following)*

- Performance Package H1: *Standard Flow Hydraulics (No Self Level)*
- Performance Package H4: *Standard Flow Hydraulics (No Self Level), Return to Dig/Work Tool Positioner, Electronic Snubbing (Raise and Lower)*
- Performance Package H5: *High Flow Hydraulics (No Self Level), Return to Dig/Work Tool Positioner, Electronic Snubbing (Raise and Lower)*

STANDARD EQUIPMENT

ELECTRICAL

- 12 volt Electrical System
- 80 ampere Alternator
- Ignition Key Start/Stop Switch
- Lights: *Gauge Backlighting, Two Rear Tail Lights, Two Adjustable Front and Rear Halogen Lights, Dome Light*
- Backup Alarm
- Heavy Duty Battery, 880 CCA

OPERATOR ENVIRONMENT

- Gauges: *Fuel Level, Hour Meter*
- Operator Warning System Indicators: *Air Filter Restriction, Alternator Output, Armrest Raised/Operator Out of Seat, Engine Coolant Temperature, Engine Oil Pressure, Glow Plug Activation, Hydraulic Filter Restriction, Hydraulic Oil Temperature, Park Brake Engaged, Engine Emission System*
- Adjustable Vinyl Seat
- Fold In Ergonomic Contoured Armrest
- Control Interlock System, when operator leaves seat or armrest raised: *Hydraulic System Disables, Hydrostatic Transmission Disables, Parking Brake Engages*
- ROPS Cab, Open, Tilt Up
- FOPS, Level I
- Top and Rear Windows
- Floor Mat
- Interior Rearview Mirror
- 12 volt Electric Socket
- Horn
- Hand (Dial) Throttle, Electronic
- Adjustable Joystick Controls
- Anti-theft Security System with 6-button Keypad
- Storage Compartment with Netting

OPTIONAL ATTACHMENTS

- External Counterweights
- Variable Speed Demand Fan
- Beacon, Rotating
- Engine Block Heater – 120V
- Oil, Hydraulic, Cold Operation
- Paint, Custom
- Product Link™, Cellular

COMFORT PACKAGE *(must select one of the following)*

- Open ROPS (C0): *Static Seat (No Foot Throttle, Headliner, Heater or Door)*
- Open ROPS (C1): *Foot Throttle, Headliner, Cup Holder, and choice of Seat (Mechanical Suspension or High Back, Heated, Air Ride Seat) (No Heater or Door)*
- Enclosed ROPS with Heater (C2): *Foot Throttle, Headliner, Heater and Defroster, Side Windows, Cup Holder, Radio Ready, choice of Seat (Mechanical Suspension or High Back, Heated, Air Ride Seat) and Door (Glass or Polycarbonate)*
- Enclosed ROPS with A/C (C3): *C2 + Air Conditioner*

POWER TRAIN

- Cat C3.3B, Turbo Diesel Engine, Meeting U.S. EPA Tier 4 Final (EU Stage IIIB) Emission Standards
- Air Cleaner, Dual Element, Radial Seal
- S-O-SSM Sampling Valve, Hydraulic Oil
- Filters, Cartridge-type, Hydraulic
- Filters, Cartridge-type, Fuel and Water Separator
- Radiator/Hydraulic Oil Cooler (side-by-side)
- Spring Applied, Hydraulically Released Parking Brakes
- Hydrostatic Transmission, Two Speed Travel
- Suspension – Independent Torsion Axles (4)

OTHER

- Engine Enclosure, Lockable
- Extended Life Antifreeze, –36° C (–33° F)
- Machine Tie Down Points (6)
- Support, Lift Arm
- Hydraulic Oil Level Sight Gauge
- Radiator Coolant Level Sight Gauge
- Radiator, Expansion Bottle
- Cat ToughGuard™ Hose
- Auxiliary, Hydraulics, Continuous Flow
- Heavy Duty, Flat Faced Quick Disconnects with Integrated Pressure Release
- Split D-Ring to Route Work Tool Hoses Along Side of Left Lift Arm
- Electrical Outlet, Beacon
- Belly Pan Cleanout

- Ride Control
- Advanced Display: Full Color, 5 in LCD screen, Advanced Multi-operator Security System, On-screen Adjustments for Implement Response, Hystat Response, and Creep Control; Rearview Camera Ready
- Advanced Display: Rearview Camera Included
- Work Tool Return to Dig and Work Tool Positioner
- Bluetooth Radio with Microphone (AM/FM/Weather Band Receiver with USB and Auxiliary Input Jack)

259D Compact Track Loader

For more complete information on Cat products, dealer services, and industry solutions, visit us on the web at www.cat.com

© 2013 Caterpillar Inc.
All Rights Reserved
Printed in U.S.A.

Materials and specifications are subject to change without notice. Featured machines in photos may include additional equipment. See your Cat dealer for available options.

CAT, CATERPILLAR, SAFETY.CAT.COM, their respective logos, "Caterpillar Yellow" and the "Power Edge" trade dress, as well as corporate and product identity used herein, are trademarks of Caterpillar and may not be used without permission.

AEHQ7010-01 (11-13)
Replaces AEHQ7010
(NACD, EU)

